



# INTERWORKING'2000

A framework architecture for interworking  
PSTN, IPv4 and IPv6

Rune Hylsberg Jacobsen

[rhj@ericssontelebit.com](mailto:rhj@ericssontelebit.com)



# Outline

- Introduction to 6INIT
- IPv6 and IPv4/IPv6 transition (briefly)
- VoIPv6 framework architecture
  - Requirements for design
  - 6INIT implementation
  - VoIPv6 transition strategies
- Motivation for SIP over IPv6, and SIP v4/v6 interworking
- 6INIT PAN European network



# What is 6INIT?

- IPv6 INternet IniTiative (<http://www.6init.org>)
- 5th EU framework programme
  - Information Society Technologies (IST)
- Duration: 16 month (due April 2001)
- Partners

BT  
Intracom  
Telscom  
E&R Group  
Netmedia  
Telia

Ericsson Telebit  
DT T-Nova  
IABG  
Univ. of Southampton  
6WIND

**Sponsoring  
partners:**

NTT  
Viaginie Inc.



## IPv6 INIT objectives

- Define, develop and deploy a Pan European IPv6 network with links to the rest of the world
- Provide a set of multimedia services including:  
Voice over IPv6
- Investigate and deploy an IPv6/IPv4 interworking mechanisms
- Trial applications and network services (IPsec, DiffServ) on the network
- Promote early IPv6-ready application and network services



# IP version 6 and transition mechanisms

- IPv6 benefits
  - Address fields of IP header extended from 32 bits to 128 bits in IPv6
  - Fixed header length (40 octets)
- IPv4/IPv6 transition mechanism
  - Dual IPv4/IPv6 stack
  - Tunnelling
  - Translation

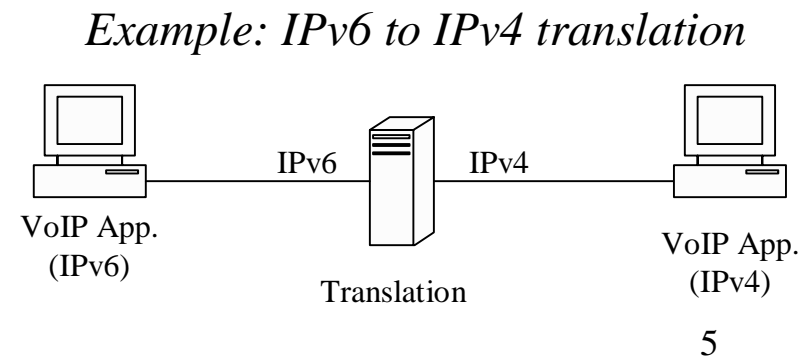



# VoIPv6 framework architecture (1)

- Requirements for design:
  - seamless interworking between PSTN, IPv4 and IPv6
  - network “independent” addressing scheme
  - cope with ongoing IPv4 to IPv6 migration
- Solution chosen:
  - Distributed gateway;
  - Dual stack and translation entities
  - A three step transition strategy



## VoIPv6 framework architecture (2)

- IETF Distributed gateway approach
  - **Signalling gateway:** Termination point for Switched circuit network signalling
  - **Media gateway controller:** Call control intelligence (Call Agent); signalling adaptation; interface to LS, AAA services, policy management etc.
  - **Media gateway:** Media adaptation at the boundary of a PSTN and IP network; transcoding; echo cancellation; silence suppression; RTP “proxy” function; compression etc.

# VoIPv6 framework architecture (3)

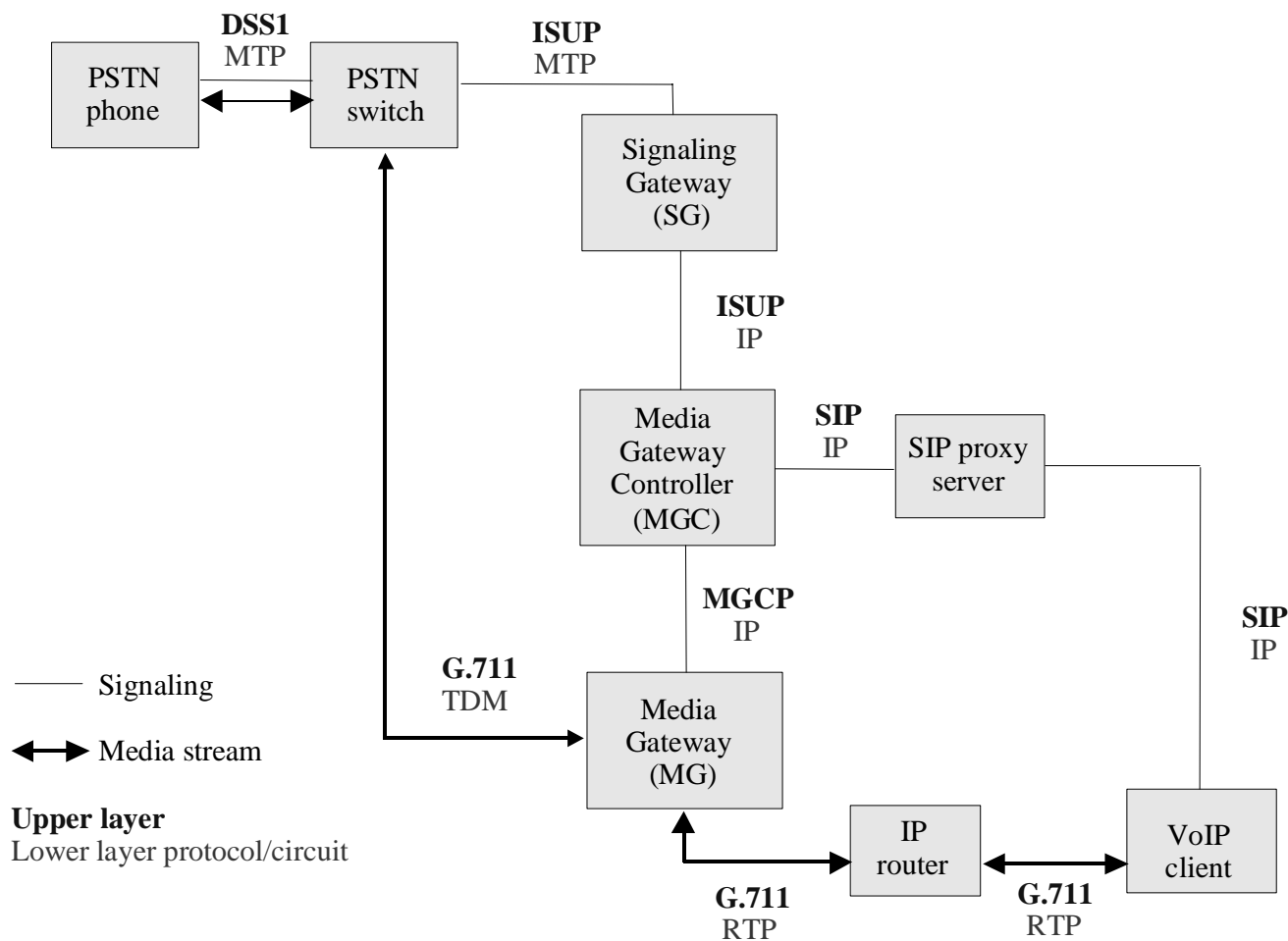

# VoIPv6 framework architecture (4)

## - 6INIT implementation -

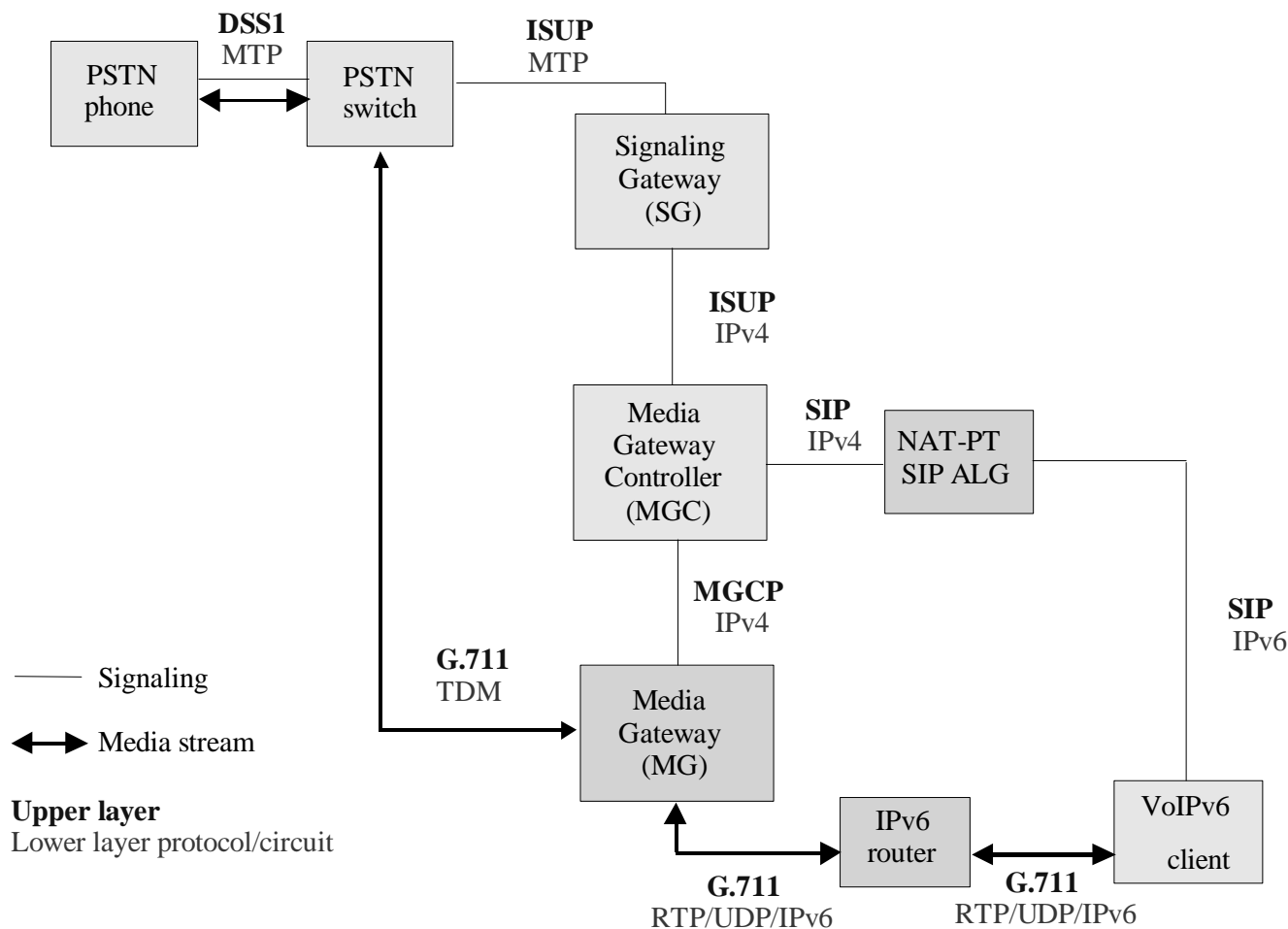



## VoIPv6 transition strategies (1)

- A three step approach
  - implement dual IPv4/IPv6 stack media gateways supporting media mapping between PSTN and IPv6. The dual-stack media gateway is under the control of an IPv4-only media gateway controllers
  - implement dual-stack media gateway controllers to control a mixed set of IPv4-only and IPv6-only media gateways
  - implement mechanisms to allow signalling between call agents in an IPv4 and IPv6 administrative domains

# VoIPv6 transition strategies (2)

**Step 1: Dual-stack MG**

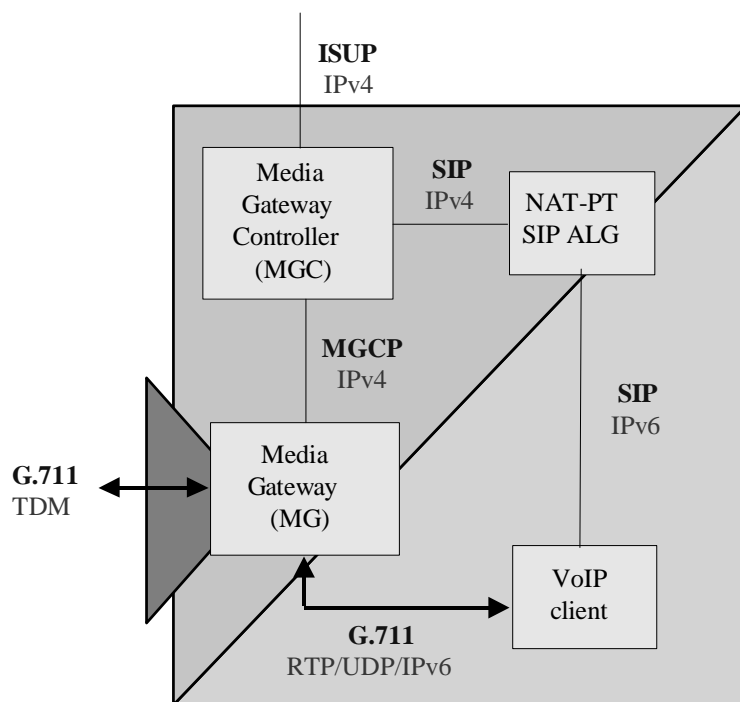

**Step 2: Dual-stack MGC**

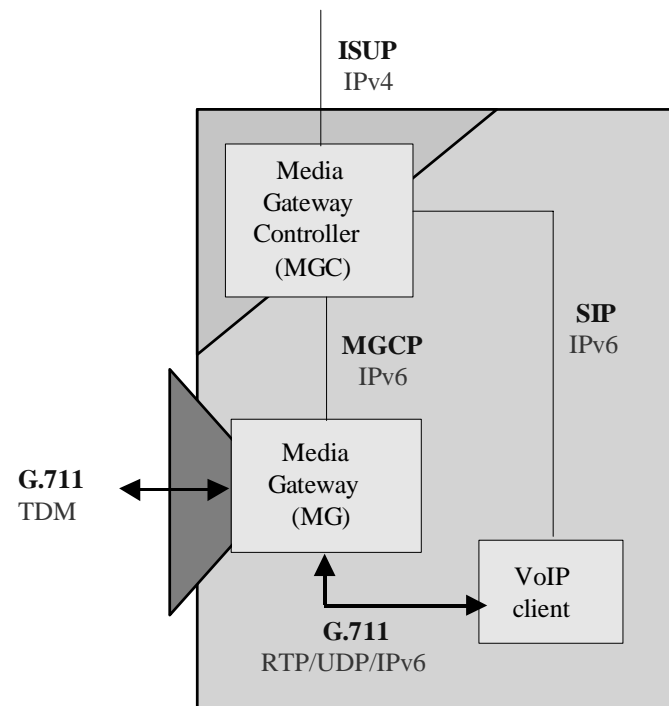

IPv4 world

IPv6 world

PSTN world

# VoIPv6 transition strategies (3)

**Step 3:** Interworking IPv4 and IPv6 administrative domains

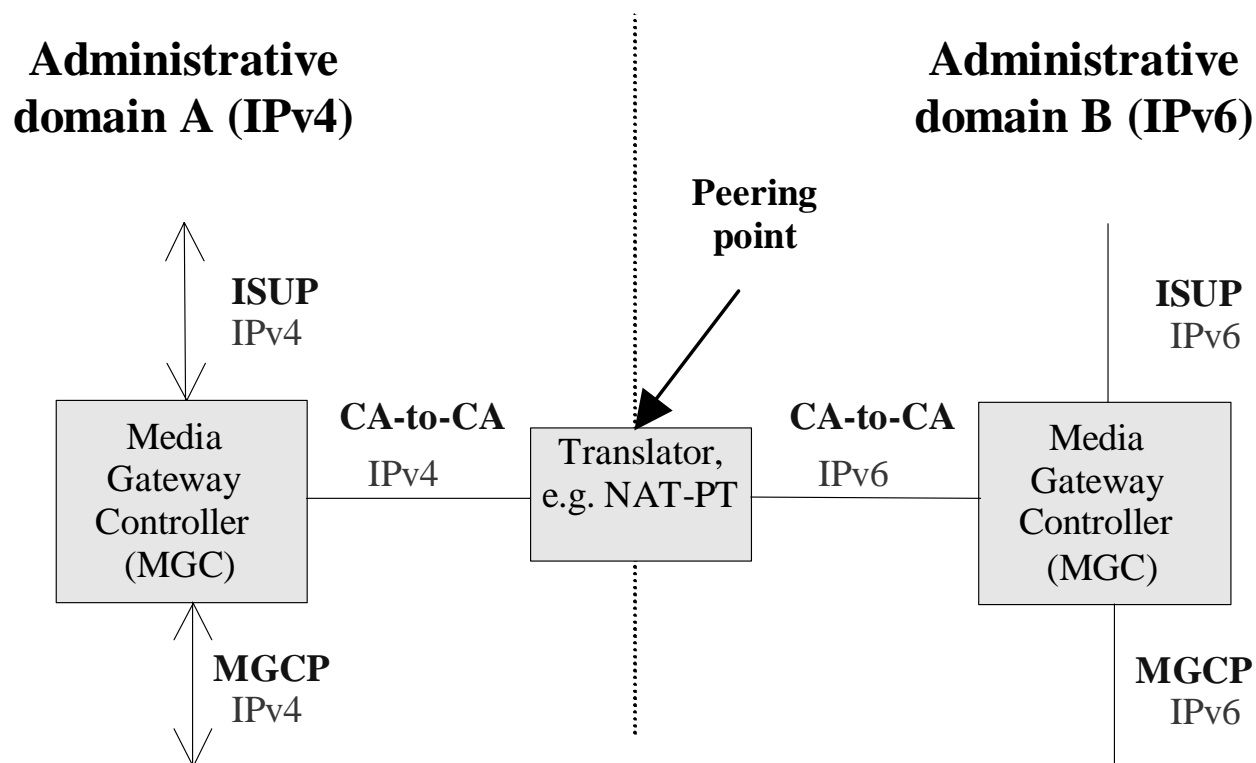



## SIP over IPv6 motivation (1)

- Session Initiation Protocol (RFC 2543)
- Rapidly gaining support as the preferred signaling protocol for IP telephony
- Client-server signaling protocol derived from HTTP
- Establishing, modifying and terminating multimedia sessions
- SIP specifies user location based on SIP URIs
- Sessions are described by SDP - RFC 2327



## SIP over IPv6 motivation (2)

- Entities of a SIP network are:
  - SIP clients (to be developed in the 6INIT project)
  - SIP servers
    - Proxy
    - Redirect (to be developed in the 6INIT project)
    - Registrar
- SIP can be implemented in a stateless manner using SIP proxy servers

# SIP over IPv6 motivation

## *SIP signalling example*

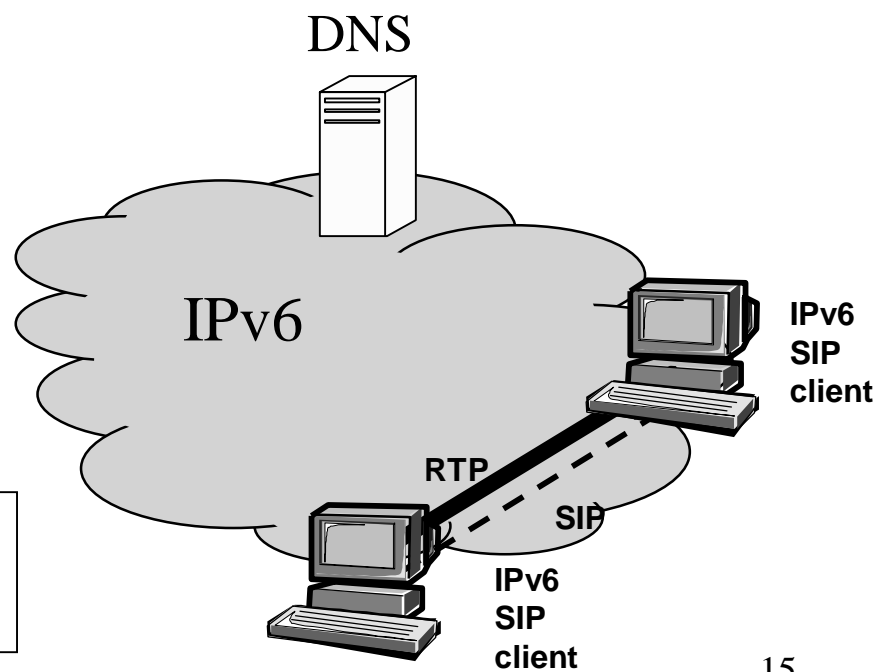
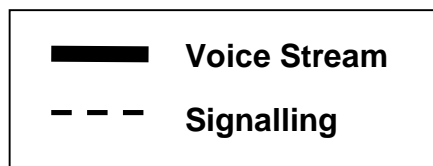
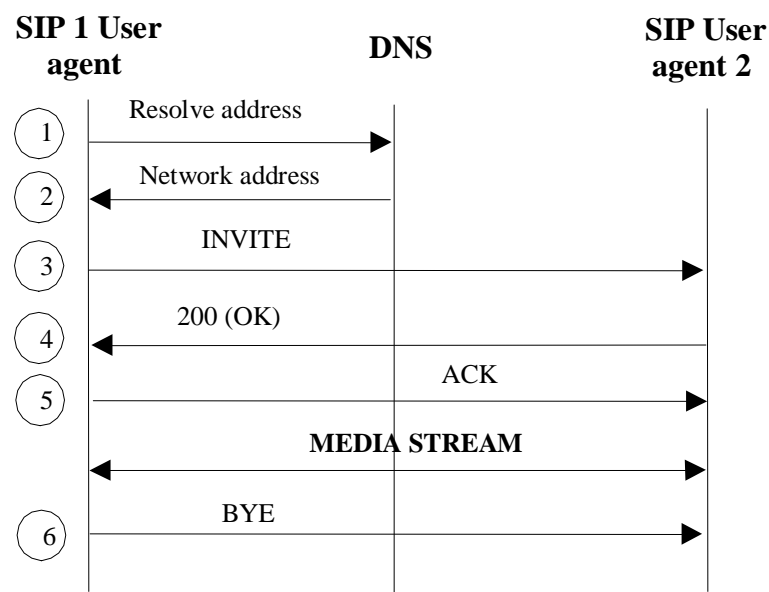

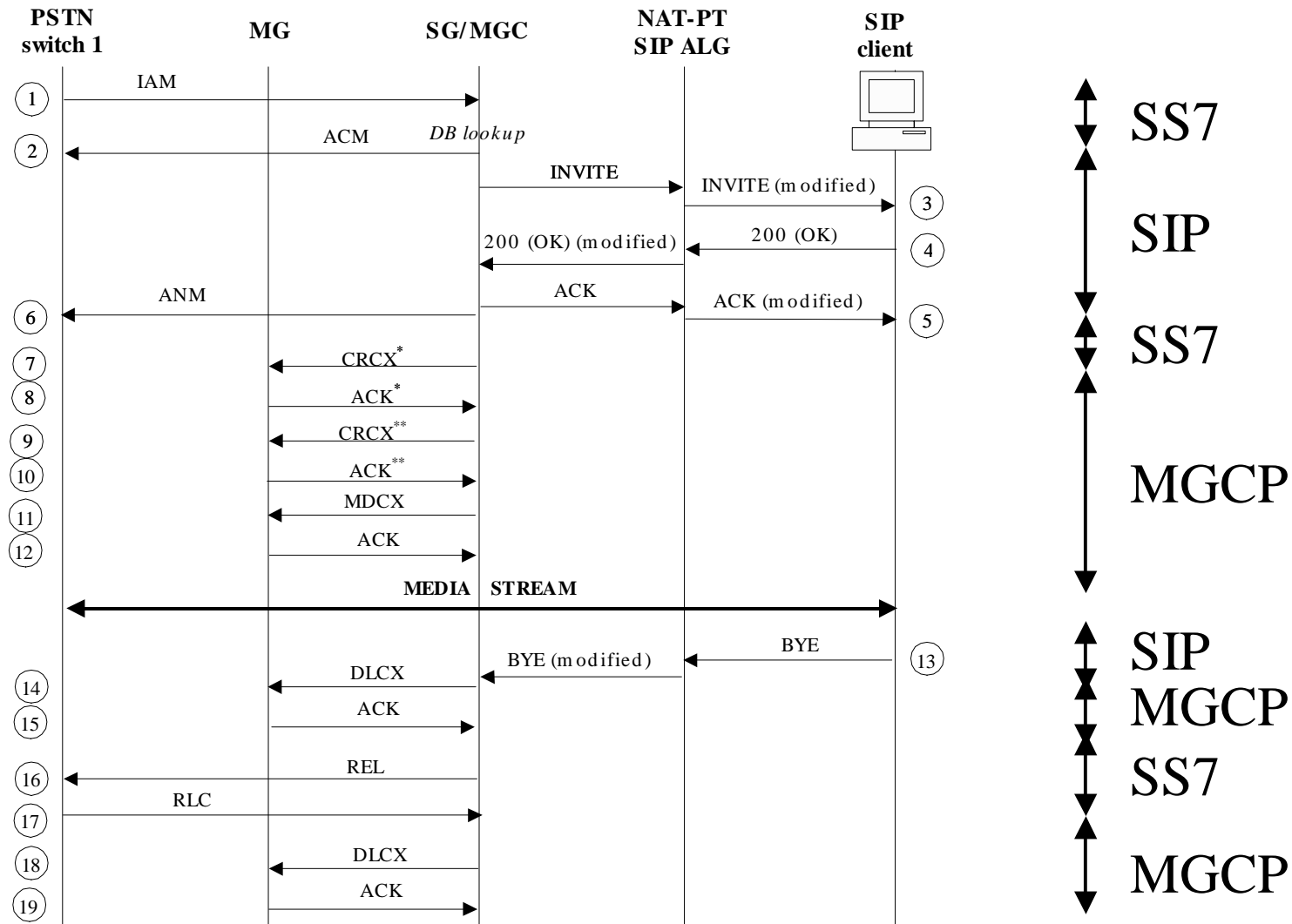

\*) Create a connection on the first endpoint, i.e. PSTN terminal

\*\*) Create a connection on the second endpoint, i.e. SIP client



## IPv4/IPv6 SIP Interworking

- NAT-PT with SIP Application Level Gateway
  - Cope with “raw” IP addresses in SIP tags: *to*, *from*, *via*
  - Cope with connect option “c=” in SDP
- Combining NAT-PT and dynamic tunnel broker seems an attractive approach in the early phase of IPv6 evolution
- Drawbacks:
  - NAT-PT is hardly a scalable approach to large networks; end-to-end security is broken

# 6INIT PAN European network

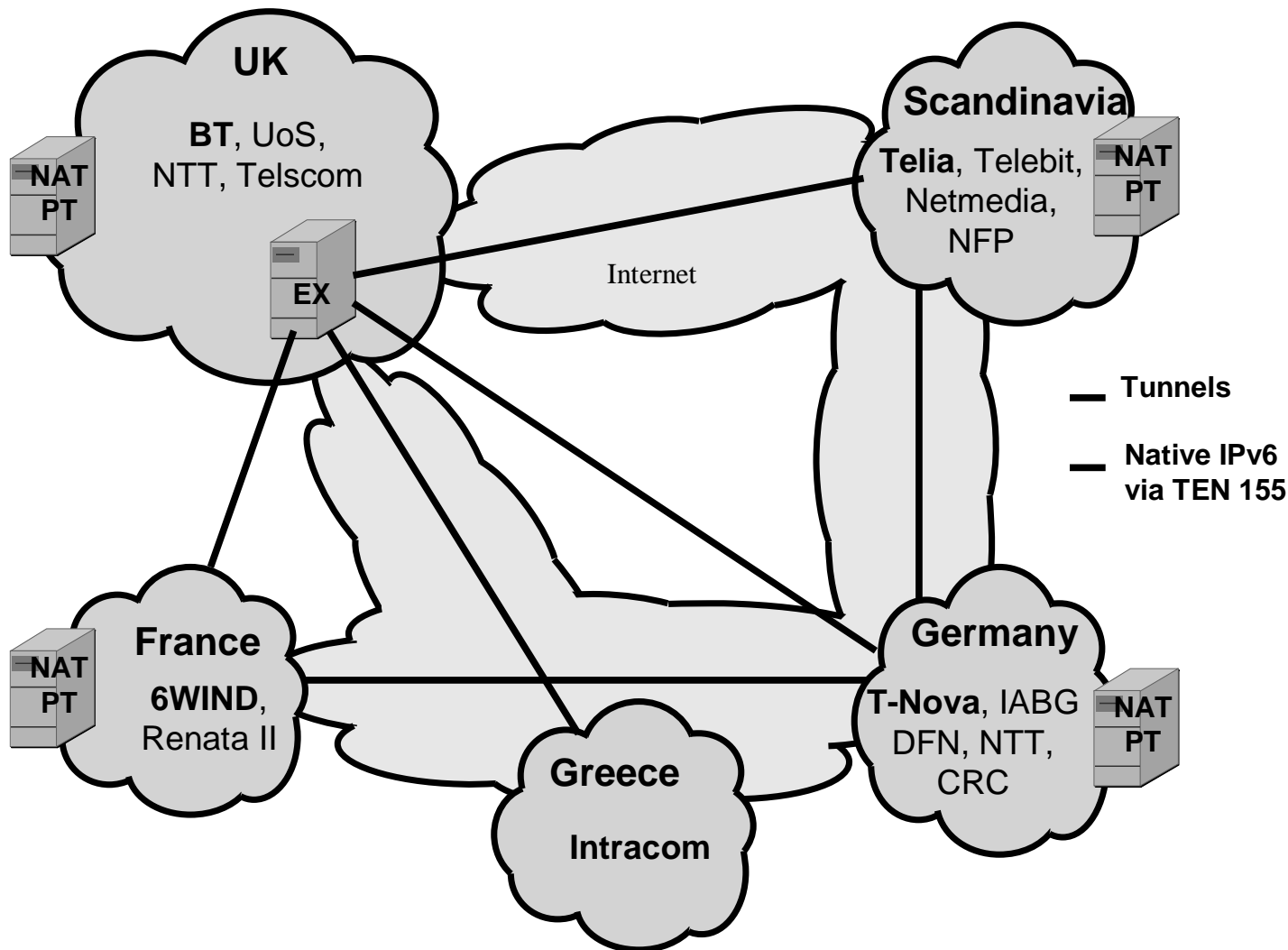



## Summary and conclusions

- VoIPv6 framework architecture that supports interworking between PSTN, IPv4 and IPv6
- Adapted to the gradual migration towards IPv6 utilising a three step approach
- Chosen SIP is the preferred signalling protocol for IPv6
- Interworking mechanisms, like NAT-PT, will be deployed to cope with signalling and data transport across IPv4/IPv6 boundaries